



# Micro-Optical MEMS, micro-mirrors and pico-projectors (Lab4MEMS II)



Duration : November 1, 2014 – October 31, 2017  
Project ID : 621176-2 (ENIAC Call 2013-2)  
Website : [www.Lab4MEMS2.ite.waw.pl](http://www.Lab4MEMS2.ite.waw.pl)

## Lab4MEMS II

will feature the Pilot Line for innovative technologies on advanced Micro-Opto-Electro-Mechanical Systems (MOEMS). This is not just a special class of MEMS systems in fact, but it deals with MEMS merged with Micro-optics, which involves sensing or manipulating optical signals on a very small size scale, using integrated mechanical, optical, and electrical systems. MOEMS includes a variety of devices including optical switch, array of micro-mirrors, optical cross-connect, lasers and micro lens amongst others. These devices are usually fabricated using micro-optics and standard micromachining technologies using materials like silicon, molybdenum (Mo), silicon dioxide, silicon nitride ( $\text{Si}_3\text{N}_4$ ), piezo coating, etc...

The key findings, including MOEMS sensor's process, design, methodology and manufacturing will be established and evaluated by means of highly impacting technology demonstrators and use-cases.

The Demonstration strategy of Lab4MEMS II is two-fold:

- A suite of "proof-of-concepts" will be delivered and assessed at midterm as intermediate demonstration vehicles to prove the actual feasibility of initial device solutions, wafer substrates, process steps, tools or equipment.
- The work-flow will then converge and optimize the set of four Final Technology Demonstrators intended to become the flagship test vehicles to demonstrate the Lab4MEMS II KET Pilot Line.

### Final Technology Demonstrators:

1. Pico-Projector (Leader: ST)
2. 3D Laser micro-scanner (Leader: ST)
3. NIR Micro-spectrometer (Leader: MURA)
4. SOI wafers for pico-projector & laser scanner (large cavity) (Leader: OKM)

## Partners

## ITE role:

ITE will be responsible for one of „proof-of-concepts” in the project - innovative applications of movable (actuated) mirror for MOEMS devices. It will be miniaturized, lightweight integrated sensor arrays system with optical readout systems. ITE works will cover design, characterization and validation activity.

ITE is also leader of dissemination and exploitation work-package in Lab4MEMS II project.



**Pico-projector** as a response to the emergence of compact portable devices such as mobile phones, personal digital assistants, and digital cameras, which have sufficient storage capacity to handle presentation of pictures/movie or slide shows but little space and power to accommodate an attached display screen. Handheld projectors can project digital images onto a white wall or a dashboard.

## Lab4MEMS – II

**3D IR Scanner**, to fit into smart-phones, laptop, ultra-books and other consumer mobile devices, or into ultra-fast 3D micro-scanners for new generation's HMI interface (games, remote control, etc.) or surveillance applications.

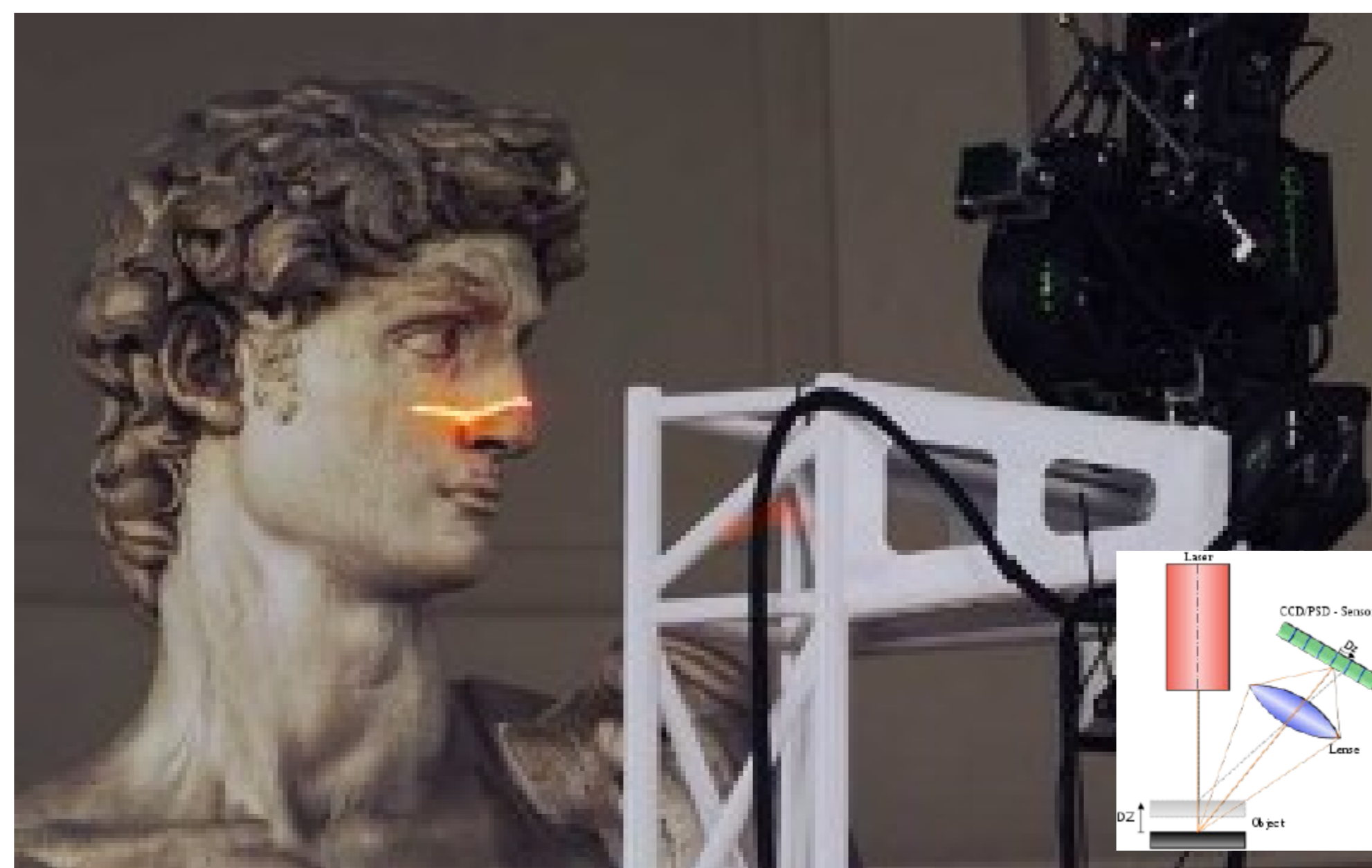

- References:
- R. Zafalon, *Photonics Pilot Line Workshop*, Brussels, November 14<sup>th</sup> 2014
  - *KET Pilot Lines at STMicroelectronics* R. Zafalon, Smart Regional Financing for KETs, Brussels, November 6<sup>th</sup> 2014
  - Lab4MEMS2 project webpage – [www.lab4mems2.ite.waw.pl](http://www.lab4mems2.ite.waw.pl)

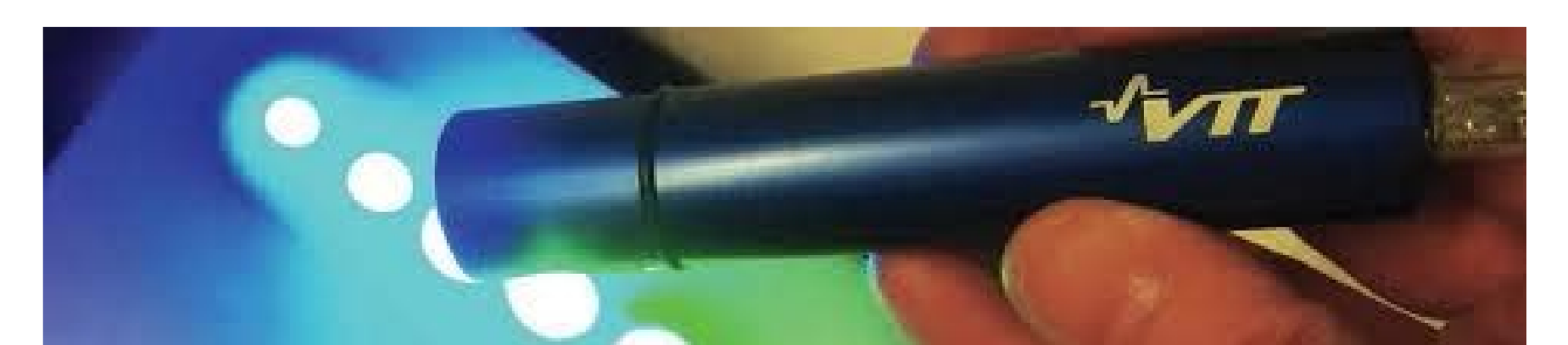
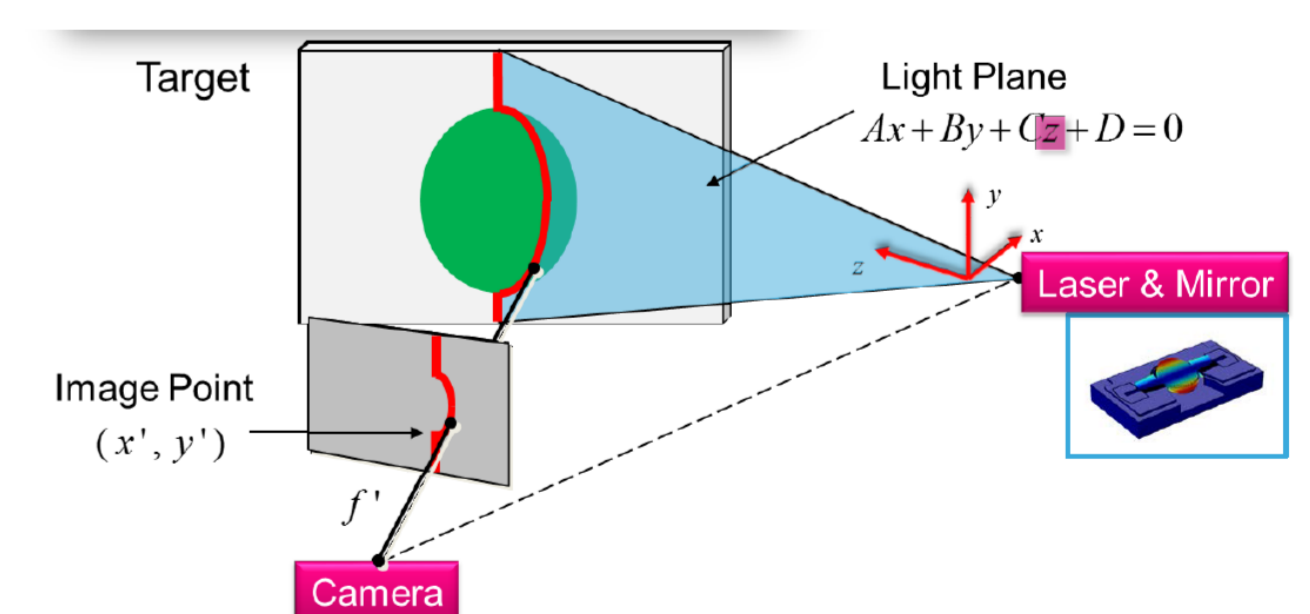

NIR microspectrometers

